

MOD:XEFT-03EU-ELDV



ENGLISH

TECHNICAL DATA

01 POWER	3,5 kW
03 FREQUENCY	50 / 60 Hz
04 POWER SUPPLY CABLE TYPE	H07RN-F
05 EXTERNAL Ø OF POWER SUPPLY CABLE	10 mm
06 VOLTAGE / POWER CABLE SECTION / CURRENT	220-240 V~1PH+PE 3G x 1,5 mm ² I1=15 A - I2= - I3= - In=
10 WATER PRESSURE	150-600 kPa
11 MAX FOOD LOAD	15 kg
13 WATER MAX CONSUMPTION	5 l/h @ 200 kPa
02 NOMINAL HEAT INPUT	3.2 kW
18 CAVITY DIMENSIONS (W - D - H)	696x441x260 mm
20 DEGREE OF PROTECTION IP	X4

ITALIANO

01 POTENZA	3,5 kW
03 FREQUENZA	50 / 60 Hz
04 TIPO DI CAVO ALIMENTAZIONE	H07RN-F
05 Ø ESTERNO CAVO DI ALIMENTAZIONE	10 mm
06 TENSIONE / SEZIONE CAVI ALIMENTAZIONE / CORRENTE	220-240 V~1PH+PE 3G x 1,5 mm ² I1=15 A - I2= - I3= - In=
10 PRESSIONE ACQUA	150-600 kPa
11 CARICA MAX CIBO	15 kg
13 CONSUMO MAX ACQUA	5 l/h @ 200 kPa
02 POTENZA TERMICA NOMINALE	3.2 kW
18 DIMENSIONI CAMERA COTTURA (L - P - H)	696x441x260 mm
20 GRADO PROTEZIONE IP	X4

FRANCAIS

01 PUISSANCE ELECTRIQUE	3,5 kW
03 FREQUENCE	50 / 60 Hz
04 TYPE DE CABLE D'ALIMENTATION	H07RN-F
05 Ø EXTERNE DU CABLE D'ALIMENTATION	10 mm
06 TENSION / SECTION CABLE D'ALIM.	220-240 V~1PH+PE 3G x 1,5 mm ² I1=15 A - I2= - I3= - In=
10 PRESSION DE L'EAU	150-600 kPa
11 CHARGE MAXIMALE D'ALIMENT	15 kg
13 CONSOMMATION MAX DE L'EAU	5 l/h @ 200 kPa
02 DEBIT THERMIQUE NOMINAL	3.2 kW
18 DIMENSIONS CHAMBRE DE CUISSON (L - P - A)	696x441x260 mm
20 INDICE DE PROTECTION IP	X4

ESPAÑOL

01 POTENCIA	3,5 kW
03 FRECUENCIA	50 / 60 Hz
04 TIPO DE CABLE DE ALIMENTACION	H07RN-F
05 Ø CABLE EXTERNO DE ALIMENTACION	10 mm
06 TENSION / SECCION CABLES DE ALIMENTACION	220-240 V~1PH+PE 3G x 1,5 mm ² I1=15 A - I2= - I3= - In=
10 PRESION AGUA	150-600 kPa
11 CARGA MAX. DE ALIMENTOS	15 kg
13 CONSUMO MAX DE AGUA	5 l/h @ 200 kPa
02 POTENCIA TERMICA NOMINAL	3.2 kW
18 DIMENSIONES CÁMARA DE COCCIÓN (An - Pr - Al)	696x441x260 mm
20 GRADO DE PROTECCION IP	X4

DEUTSCH

01 ELEKTRISCHE LEISTUNG	3,5 kW
03 FREQUENZ	50 / 60 Hz
04 ZULEITUNGSKABELTYP	H07RN-F
05 AUSSENDURCHMESSER DES VERSORGUNGSKABELS	10 mm
06 KABELQUERSCHNITT UND VERSORGUNGSSPANNUNG	220-240 V~1PH+PE 3G x 1,5 mm ² I1=15 A - I2= - I3= - In=
10 WASSERDRUCK	150-600 kPa
11 MAX. SPEISENFASSUNGSVERMOGEN	15 kg
13 MAXIMUM WASSERVERBRAUCH	5 l/h @ 200 kPa
02 NOMINALE WARMELEISTUNG	3.2 kW
18 GRÖÖBE DES KOCHKAMMERS (B - T - H)	696x441x260 mm
20 SCHTZART IP	X4

MOD:XEFT-03EU-ELDV



ENGLISH - DRAWINGS	
2	TERMINAL BOARD POWER SUPPLY
3	UNIPOTENTIAL TERMINAL
6	TECHNICAL DATA PLATE
7	SAFETY THERMOSTAT
8	3/4" THREAD WATER INLET
12	HOT FUMES EXHAUST CHIMNEY
13	ACCESSORIES CONNECTION
27	COOLING AIR OUTLET

ITALIANO - DISEGNI	
2	MORSETTIERA ALIMENTAZIONE
3	MORSETTO EQUIPOTENZIALE
6	TARGHETTA DATI TECNICI
7	TERMOSTATO DI SICUREZZA
8	INGRESSO ACQUA 3/4"
12	USCITA FUMI CALDI
13	COLLEGAMENTO ACCESSORI
27	USCITA ARIA DI RAFFREDDAMENTO

FRANCAIS - ENCOMBREMEN	
2	BOITE A BORNES D'ALIMENTATION
3	SUPPORT BORNE EQUIPOTENTIELLE
6	PLAQUETTE SIGNALÉTIQUE
7	THERMOSTAT DE SÉCURITÉ
8	ARRIVÉ D'EAU FIÉLT 3/4"
12	SORTIE DES FUMÉES CHAUDES
13	JONCTION DES ACCESSOIRES
27	SORTIE D'EAU DE REFROIDISSEMENT

ESPAÑOL - DISEÑOS	
2	CAJA DE CONEXION
3	SEDE BORNE EQUIPOTENCIAL
6	TARJETA DE CARACTERISTICAS TECNICAS
7	TERMOSTATO DE SEGURIDAD
8	ENTRADA DE AGUA 3/4"
12	SALIDA HUMOS CALIENTES
13	CONEXION ACCESORIOS
27	SALIDA DEL AIRE DE ENFRIAMIENTO

DEUTSCH - ZEICHNUNGEN	
2	ZULEITUNGSKLEMMLEISTE
3	GLEICHPOTENTIELLE KLAMMER
6	TYPENSCHILD
7	SICHERHEITSTHERMOSTAT
8	WASSEREINZUG 3/4" GEWINDE
12	ABZUGSHAUBE
13	ZUBEHÖRTEILENVERBINDUNG
27	KÜHLLUFTAUSTRITT

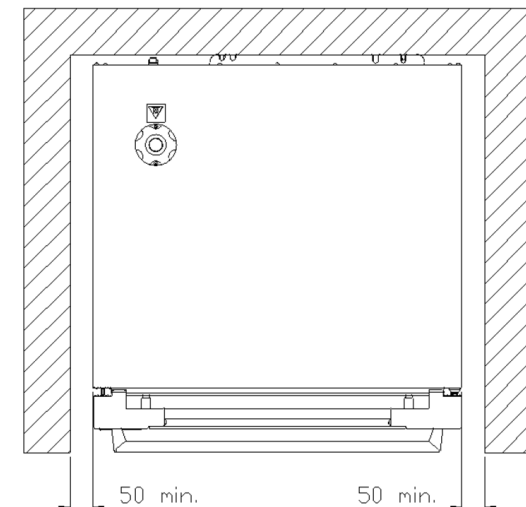
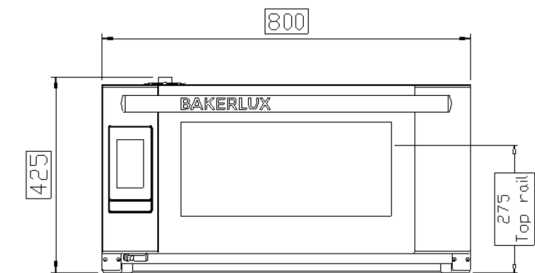
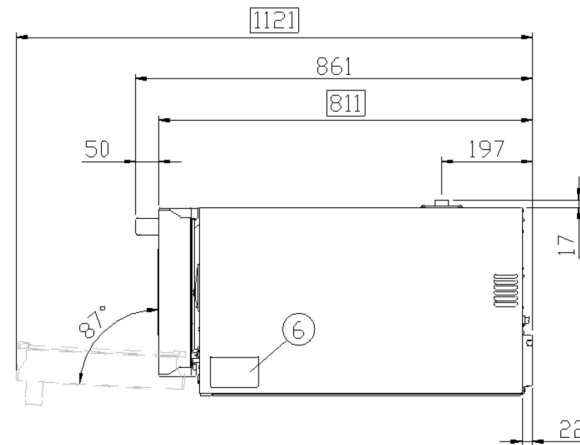
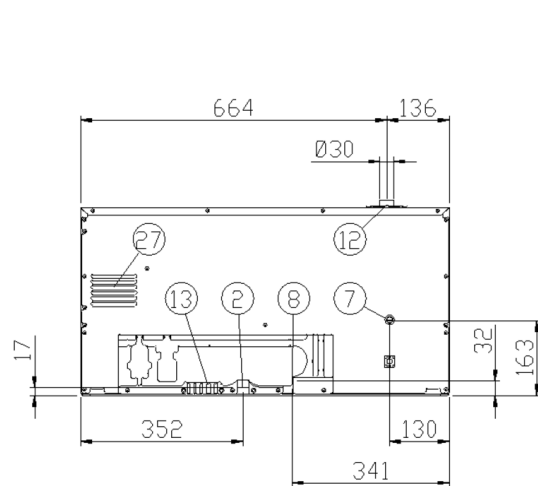

MOD:XEFT-03EU-ELD V

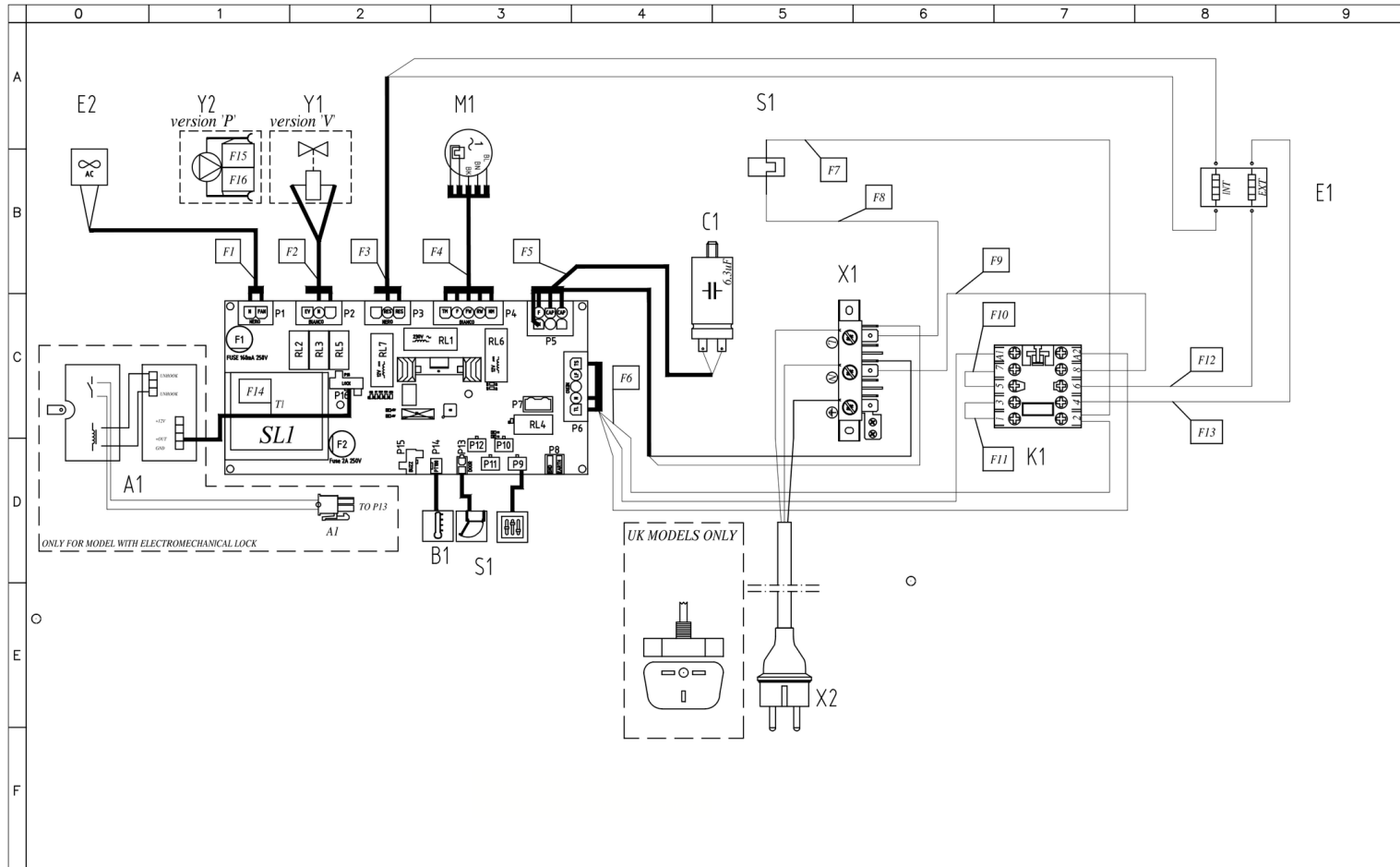

						Impianto XEFT-04HS-EG		FOGLIO 1
						Denominazione ARIANNA		SEGUE 2
00	PRIMO RILASCIO	19/04/17				Nome File XEFT-04HS-EG		
REV.	MODIFICA	DATA	DISEGNATORE	VISTO				

MOD:XEFT-03EU-ELDV



	0	1	2	3	4	5	6	7	8	9
A										
	<i>Sigle</i>	<i>ENGLISH</i>	<i>ITALIANO</i>	<i>FRANCAIS</i>	<i>ESPAÑOL</i>	<i>DEUTSCH</i>				
	<i>C1</i>	<i>MOTOR CAPACITOR</i>	<i>CONDENSATORE</i>	<i>CONDENSATEUR</i>	<i>CONDENSADOR</i>	<i>KONDENSATOR</i>				
	<i>K1</i>	<i>CONTACTOR</i>	<i>TELERUTTORE</i>	<i>TELERUPTEUR</i>	<i>TELERRUPTOR</i>	<i>RELAIS</i>				
B	<i>SL1</i>	<i>POWER CARD</i>	<i>SCHEDA POTENZA</i>	<i>CARTE DE PUISSANCE</i>	<i>TARJETA POTENCIA</i>	<i>POWERPLATINE</i>				
	<i>X1</i>	<i>CONTACTOR</i>	<i>MORSETTIERA</i>	<i>BORNIER</i>	<i>CONECTOR</i>	<i>KLEMMLEISTE</i>				
	<i>X2</i>	<i>POWER CORD + SCHUKO</i>	<i>CAVO ALIMENTAZIONE + SCHUKO</i>	<i>E'PINI'ERE ET SCHUKO</i>	<i>CABLE Y ENCHUFE SCHUKO</i>	<i>KABEL UND SCHUKO-STECKER</i>				
	<i>E1</i>	<i>HEATING ELEMENT</i>	<i>ELEMENTO RISCALDANTE</i>	<i>ELEMENT DE CHAUFFAGE</i>	<i>RESISTENCIA DE CALEFACCIÓN</i>	<i>HEIZUNG</i>				
	<i>E2</i>	<i>COOLING FAN 230V</i>	<i>VENTOLA RAFFREDDAMENTO 230V</i>	<i>TURBINE DE REFROIDISSEMENT 230V</i>	<i>TURBINA DE REFRIGERACION 230V</i>	<i>LÜFTER 230V</i>				
C	<i>M1</i>	<i>MOTOR</i>	<i>MOTORE</i>	<i>MOTEUR</i>	<i>MOTOR</i>	<i>MOTOR</i>				
	<i>S1</i>	<i>SAFETY THERMOSTAT</i>	<i>TERMOSTATO SICUREZZA</i>	<i>THERMOSTAT DE SECURITE</i>	<i>TERMOSTATO DE SEGURIDAD</i>	<i>SICHERHEITS THERMOSTAT</i>				
	<i>Y1</i>	<i>WATER SOLENOID VALVE</i>	<i>ELETTROVALVOLA ACQUA</i>	<i>ELECTROVANNE EAU</i>	<i>ELECTROVALVULA</i>	<i>ELEKTROVENTIL</i>				
D										
E										
F										
							Impianto XEFT-04HS-EG		FOGLIO 2	
							Denominazione ARIANNA		SEGUE /	
00	PRIMO RILASCIO		19/04/17							
REV.	MODIFICA		DATA	DISEGNATORE	VISTO		Nome File XEFT-04HS-EG			